



PHILIPS
LUMILEDS

5 YEAR
WARRANTY



GENERAL DESCRIPTION

- LED, high luminous efficiency and long working life.
- High efficiency LED Driver, the wide range input voltage AC100-277V.
- Cast aluminum cooling design, better cooling, light in weight, LED Tj < 85°C.
- Excellent Optics design, greatly improve the light utilization and evenness.
- Photocell Control Available (Option)

APPLICATION

AL LED WALL PACK Lighting series can be widely used in indoor or outdoor lighting (Wet location), like mechanical or electronic processing workshops, storage warehouses, steel mills, gas stations, toll booth, waiting rooms, the platforms of railway station, indoor stadiums and flower cultivating tents etc.

DIMENSIONS

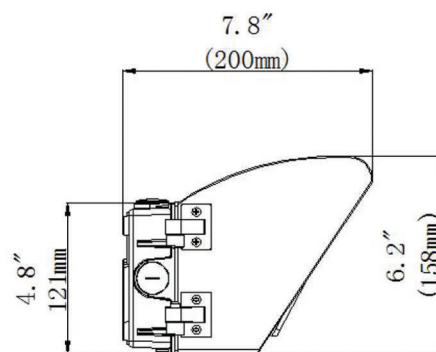
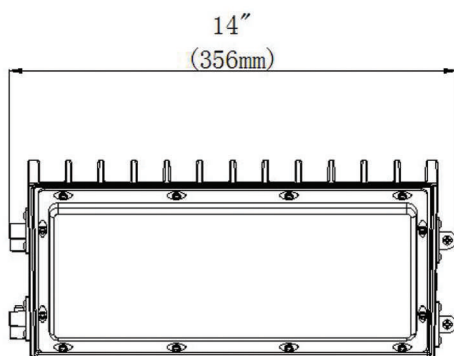

Structure Features

- Shell materials: Aluminum & PC.
- Finish: Dark Bronze/White
- Net weight: 3.50kgs
- Unit: inch(mm)
- Packing Size: 400mm*260mm*228mm

LIGHTING UP THE WORLD
WITH ONE BULB AT A TIME!

TECHNICAL PARAMETERS

Type	AL-HWP07W27-XXK		
Power	70W	Lighting Angle	60*90°
Input Voltage	AC100-277V	LED Brightness Decay	<5%/6000 hrs
PF	>0.95	Working Life	>50000 hrs
Driver Efficiency	>90%	Working Temperature	-30 - +45°C
Luminous Flux	7200 Lm	Storage Temperature	-40 -+80°C
Color Temperature	3000K/4000k/5000K/6500K	Protection Level	Wet Location/IP65
CRI	Ra>80	Cable	Input Connect, No cable

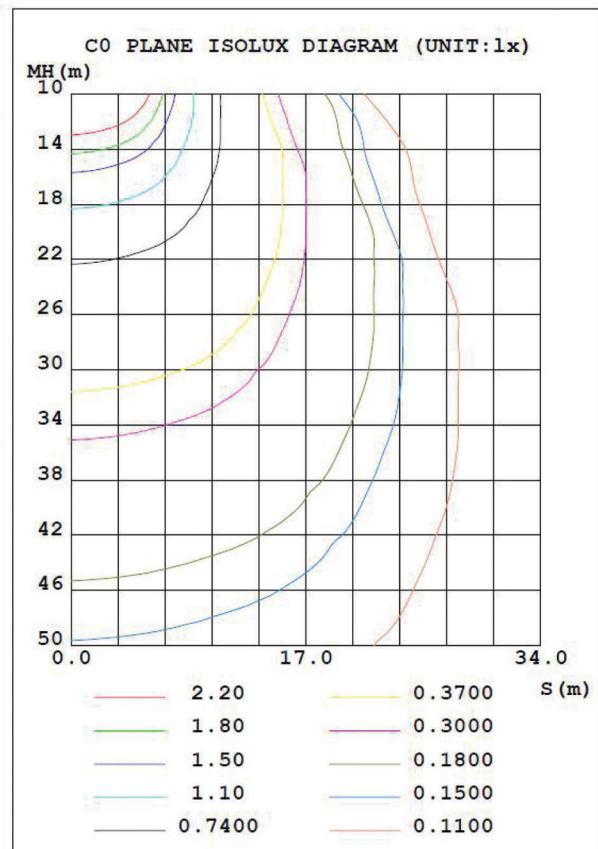
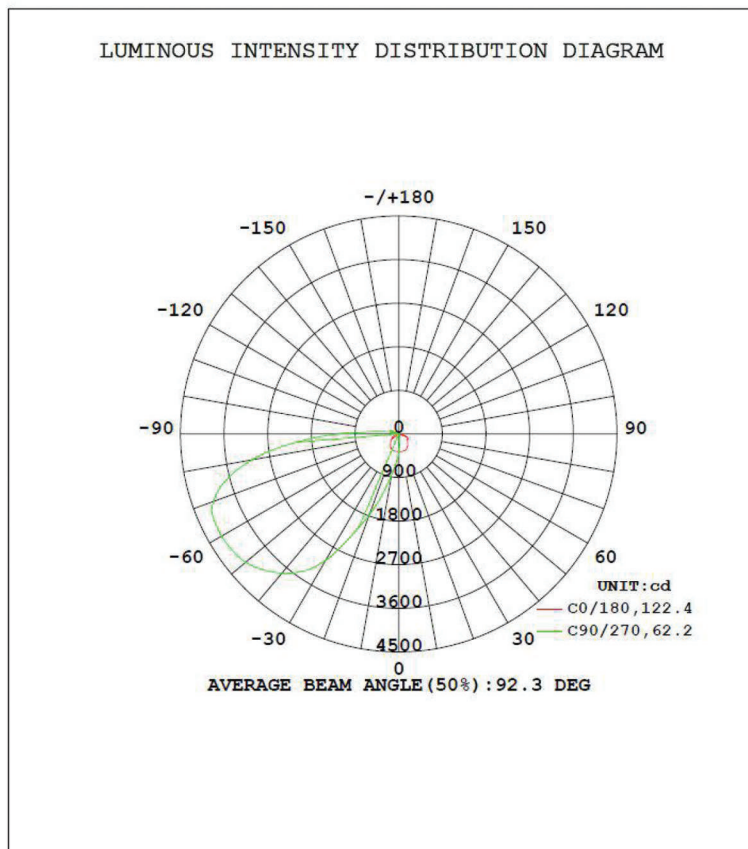

LIGHTING UP THE WORLD
WITH ONE BULB AT A TIME!